

120VAC ILLUMRA 4-WAY SWITCH WIRING DIAGRAM
 USES TWO HARD-WIRED SWITCHES AND
 ONE ILLUMRA RELAY RECEIVER AND
 UP TO 30 ILLUMRA BATTERY-FREE WIRELESS SWITCHES

NOTE: PLEASE REFER TO THE SPECIFICATIONS FOUND IN THE USER MANUAL FOR THE WIRE-IN RELAY. THE CONTACT RATINGS FOR THE N.O. CONTACTS ARE DIFFERENT THAN THE CONTACT RATINGS FOR THE N.C. CONTACTS. TAKE CARE TO OPERATE THE WIRE-IN-RELAY IN COMPLIANCE WITH BOTH N.O. RATINGS AND N.C. RATINGS.

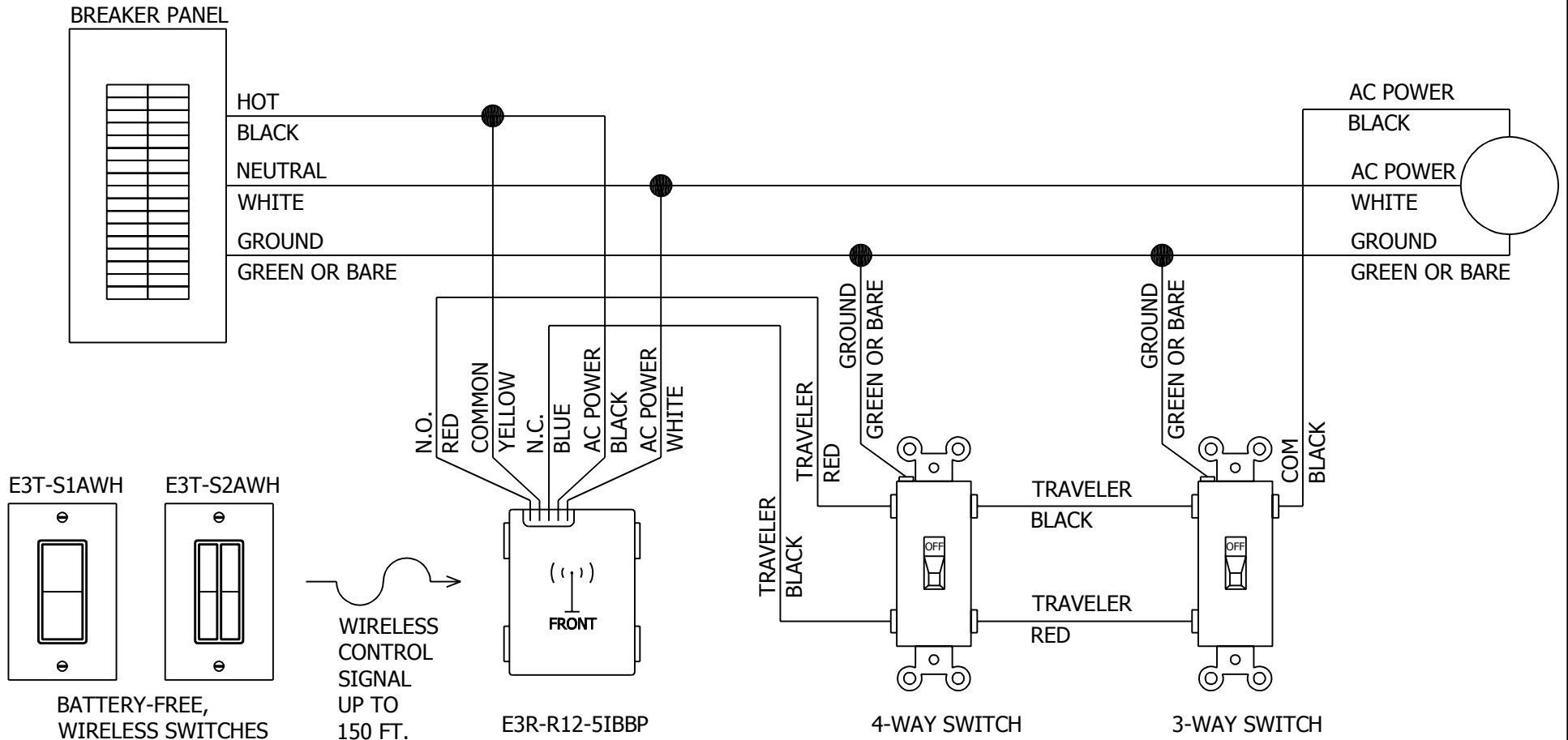

INSTALLATION SHOULD BE PERFORMED BY A QUALIFIED ELECTRICIAN AND IN ACCORDANCE WITH LOCAL REGULATIONS.