

20A On/Off Area Controller

Installation Guide

Control any 20A compatible load (including LED drivers, fluorescent ballasts, motor controllers, actuators, and more) using signals from wireless gateways. The Area Controller is compatible with all 120VAC, 240VAC, or 277VAC circuits.

SPECIFICATIONS

Electrical

Power Input: 100-277 VAC 50 or 60 Hz
Standby Power: <0.5W
Max Power Use: <0.5W

Outputs

1 - 20A Latching Form A Relay

Inputs

1 - Zigbee Wireless Antenna

Maximum Load

20A
General Duty: 20A
Tungsten (Incand.): 20A
Fluorescent Ballast: 20A
Motor Load: 1/3HP
Max Inrush: 160A

Wireless

Range: 50-150 feet (typical)
Frequency: 2.4 GHz

Mounting: Outside of junction box w/ threads or inside junction box (metal reduces range)

ZigBee Support: HA1.2

Dimensions: 2.11 x 1.73 x 1.09 inches
(54 x 44 x 28 mm)

Operating Specifications

Operating Temp: 32° to +122°F (0° to +50°C)
Storage Temp: -4° to +176°F (-20° to +80°C)
Humidity: 10-90% non-condensing

Certifications

ETL: UL 60730 (U.S.), CSAc22.2#14-05 (Canada), UL 2043 (Plenum)
FCC: W7Z-ZICM357SP2 (United States)
IC: 8254A-ZICM357SP2 (Canada)

Compatible Devices

Wireless Gateway

ZigBee Profiles

HA1.2

Package Contents

(1) Controller
(1) Instruction Sheet

Equipment Needed

• Wire Nuts/Connectors
• Electrical Tape

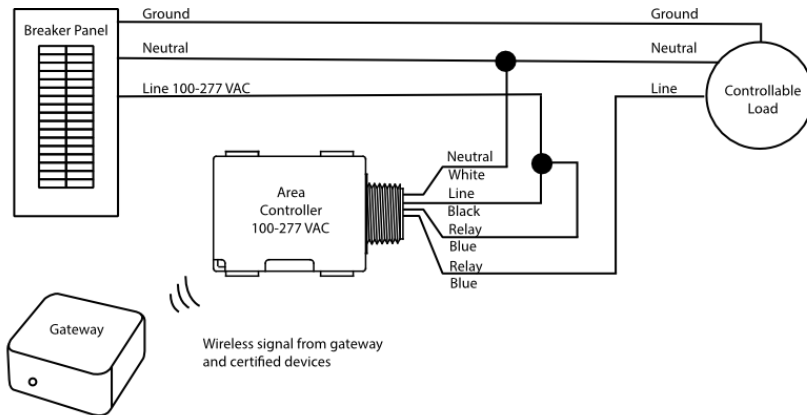

CAUTION:

- This product is intended only for use indoors and in dry locations.
- For best results, pair wireless gateway to Area Controller prior to final installation.
- Install and use in accordance with these instructions, electrical codes, and regulations.
- If unsure about any part of these instructions, consult an electrician.

CHOOSE THE OPTIMAL MOUNTING LOCATION

The long-term reliability and wireless performance of the Area Controller is strongly influenced by the mounting location. Choose a mounting location carefully.

For best radio performance:

- Create separation distance away from interfering electronics such as fluorescent tube ends, electronic transformers, power supplies, motors, etc.
- Mounting inside metal enclosures reduces the range.
- Obstructions of metal, concrete, and dense building materials will reduce the range. Mount higher and away from obstructions to maximize the range.
- Installation above a hot fixture may result in overheating or melting. Confirm operating environment does not exceed temperature or humidity specs.
- Site survey tools are available to help fine-tune wireless communications.

INSTALLATION

1. **PLAN** - Identify best mounting locations for receiver and transmitter. Perform range test to confirm operation prior to installation. Turn breaker OFF before making connections.
2. **CONNECT** - Make connections to the Area Controller following wiring diagram and local electrical codes. Restore power.
3. **TEST** - Press ON button to turn output ON. Press OFF button to turn output OFF.
4. **PAIR** - Pair wireless gateway and Area Controller following pairing instructions below.

OPERATION

Use the Area Controller to switch power to loads. Compatible loads include 0-10V controlled LED and fluorescent lighting, motors, etc.

PAIRING INSTRUCTIONS

Note: The Area Controller must be powered on while pairing. After pairing, the Area Controller retains all network settings in the event of power loss.

1. Power the Area Controller.
1. Initiate pairing sequence from the gateway using mobile app.

ADDITIONAL FUNCTIONS

TEST FUNCTION:

Press and release the ON button to turn output ON.
Press and release the OFF button to turn output OFF.

RESTORE FACTORY DEFAULTS

Hold OFF button until status LED begins to blink and then release quickly (within 5 seconds) to clear.

LED Status Light

- GREEN - indicates output is ON
- RED - indicates output is OFF
- ORANGE BLINKING (SLOW) - controller is not connected to a network
- ORANGE BLINKING (FAST) - indicates that the OFF button has been pressed long enough to RESTORE FACTORY DEFAULTS

Note: ORANGE BLINKING will occur simultaneously with RED or GREEN indicators

